

1U HD INSTALLATION GUIDE

HD Chassis

HD PANEL 1U

Table of Contents

Body Installation.....	3
Rear Cabling.....	6
Front Cabling	8

1. Body Installation

1.1: Install 3 cage nuts in each side of the mounting profiles.

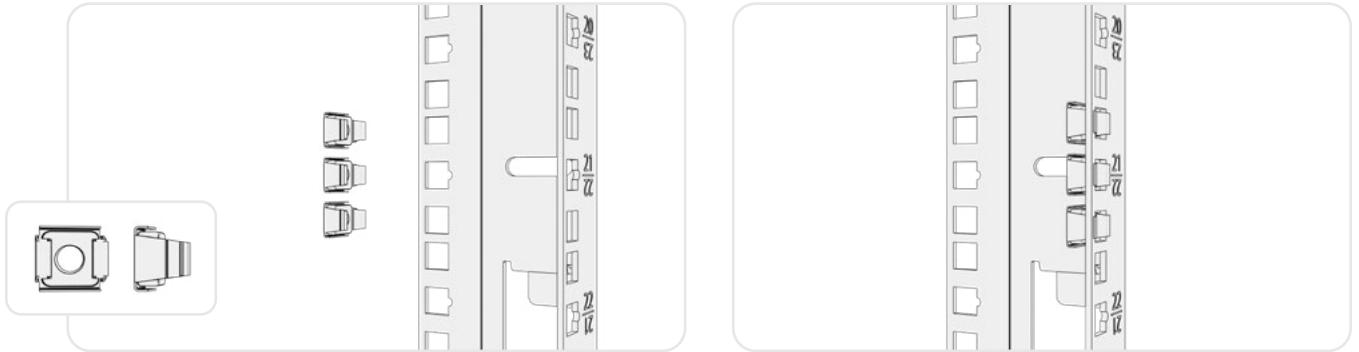

1.2: Install the bottom cage screw each side.

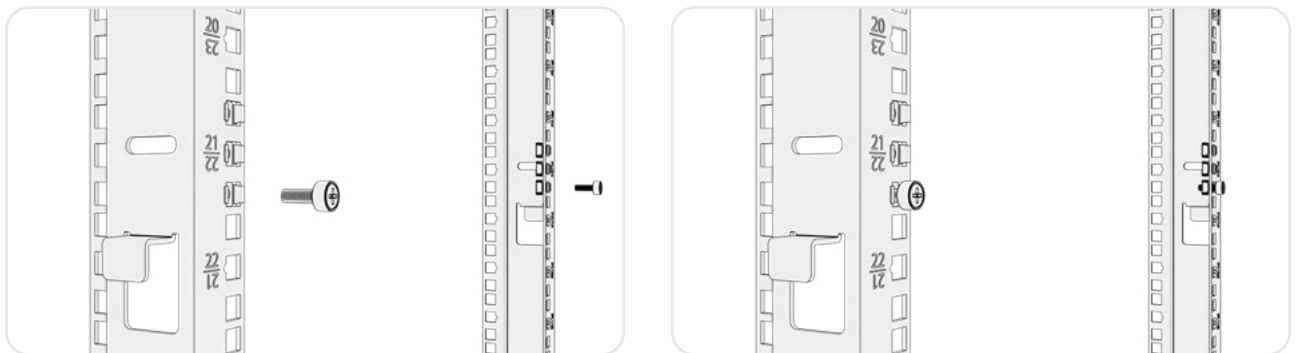

1.3: Mount the panel onto the bottom screw allowing the panel to rest on them.

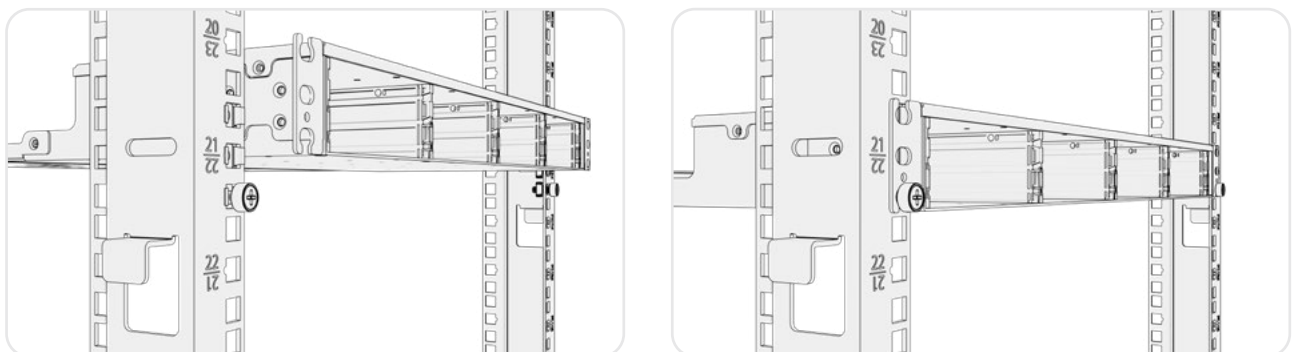

1.4: Install the remaining top 2 screws leaving the central cage nut empty.

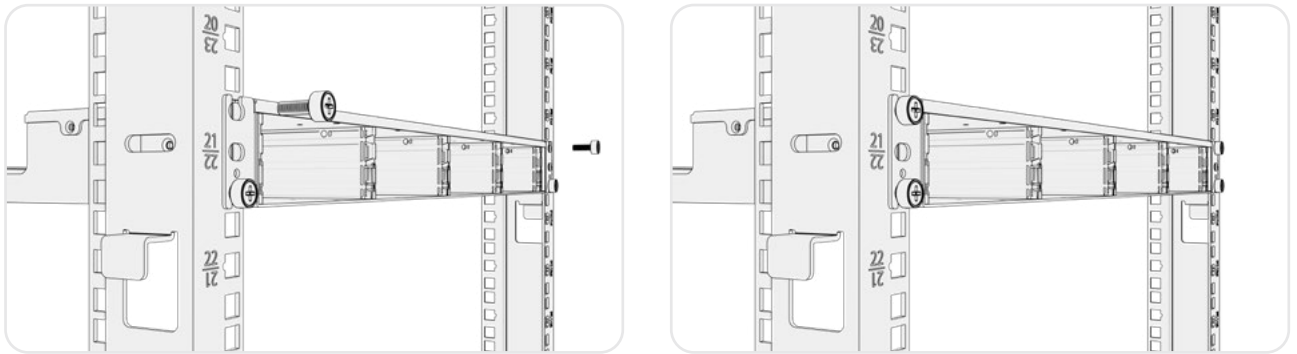

1.5: Tighten all screws ensuring the panel is level and within the designated U space.

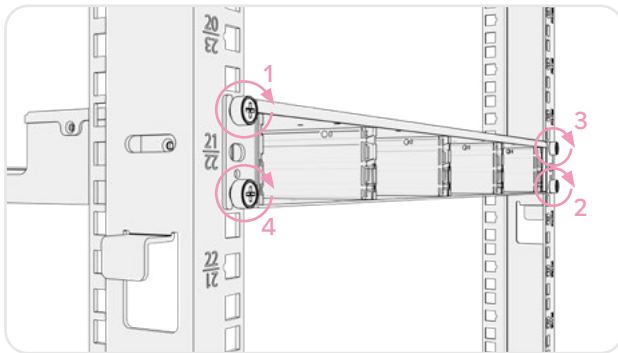

1.6: Install the front management panel using the central cage nut point.

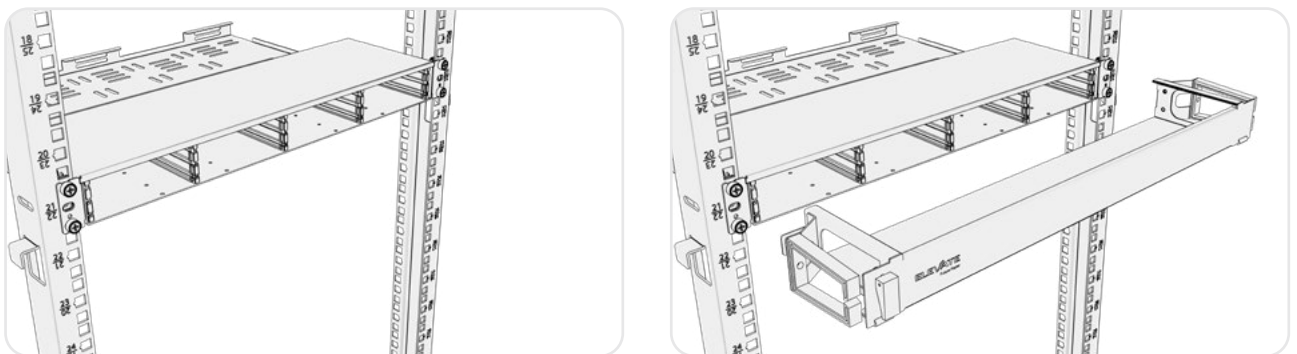

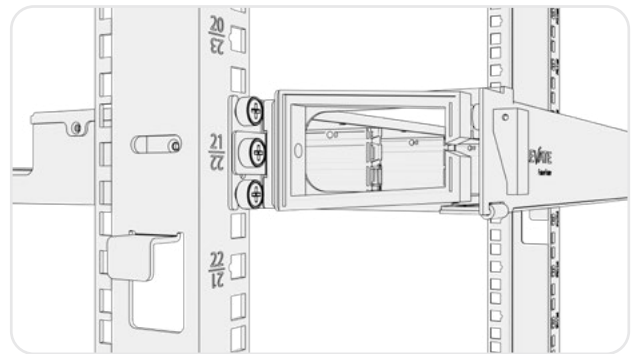
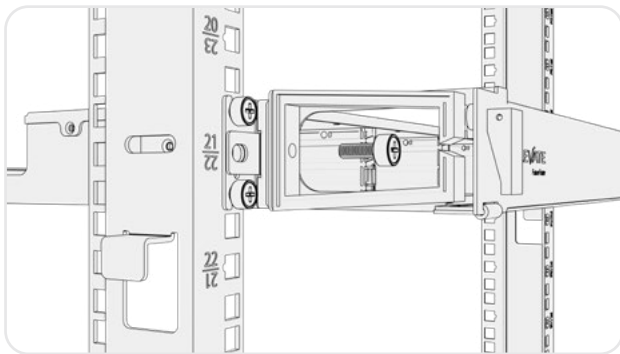
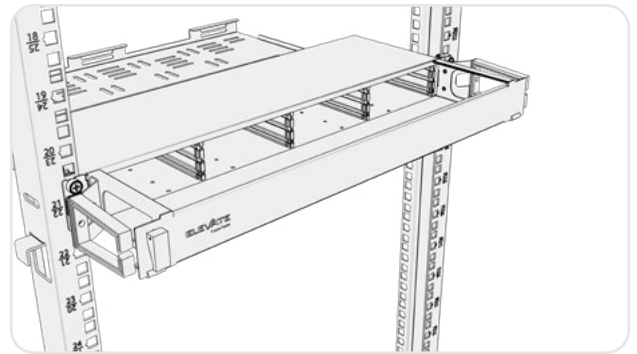
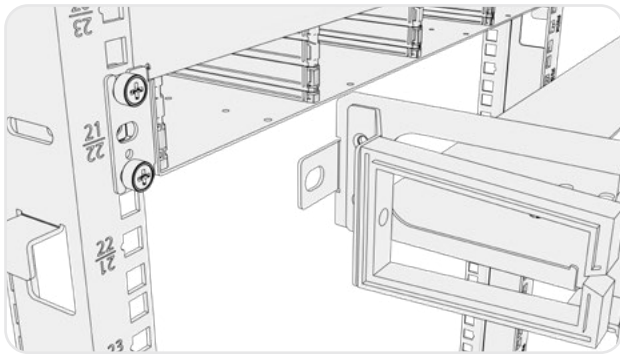

1.7: Install desired cassettes.

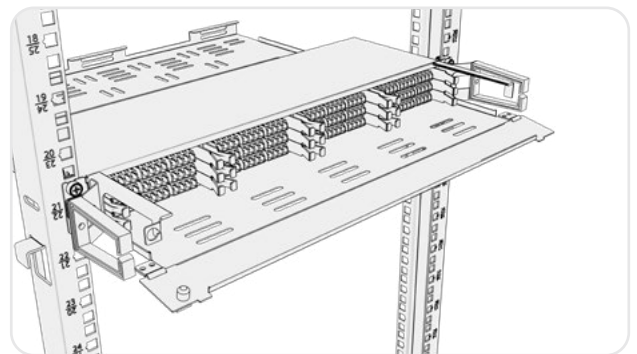
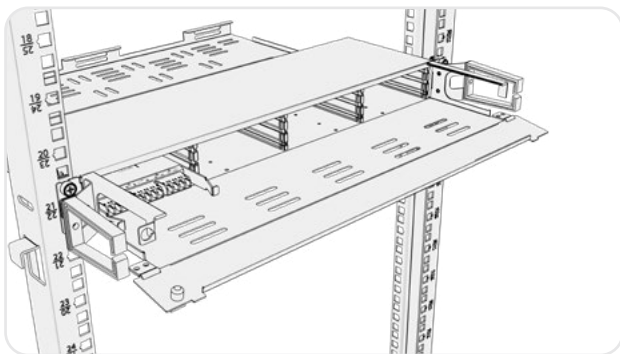
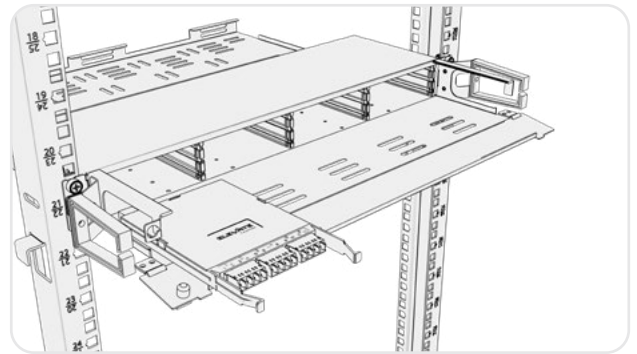
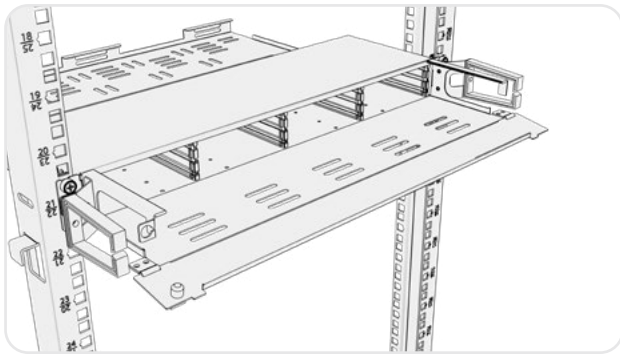

2. Rear Cabling

2.1: Clean all end faces of the MPO Connections on the incoming Trunk cable profiles with lint free dry clean cloth.

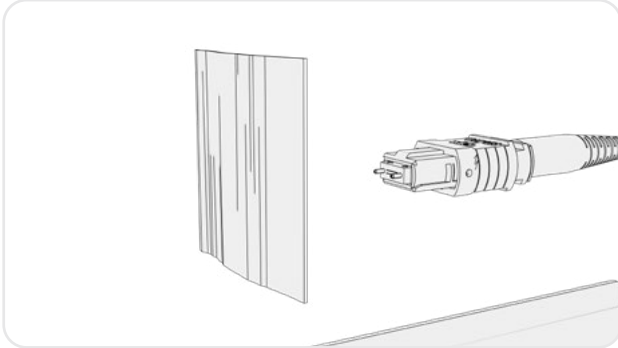

2.2: Clean all end faces on the Cassette MPO connections.

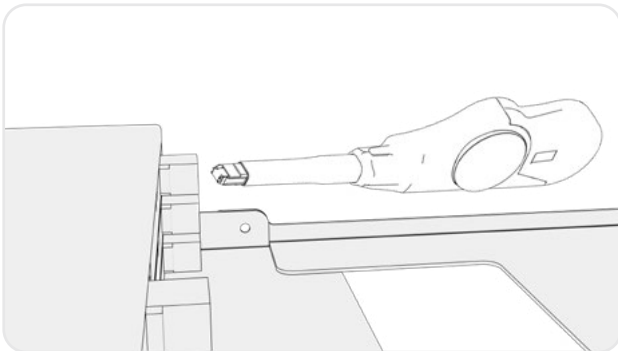

2.3: Insert all MPO to the back of the cassettes.

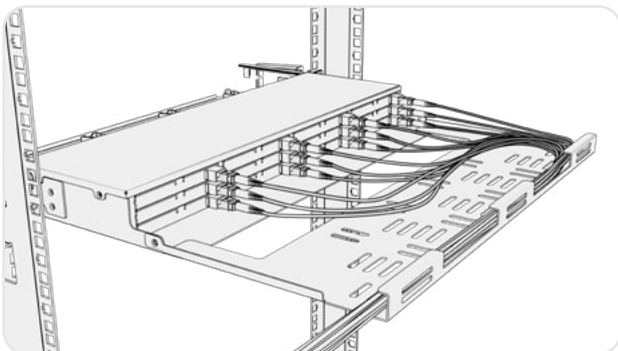

2.4: Dress the tails of the trunk cable in a swan neck shape this allows slack to remove the cassettes when needed (600mm tails are recommended).

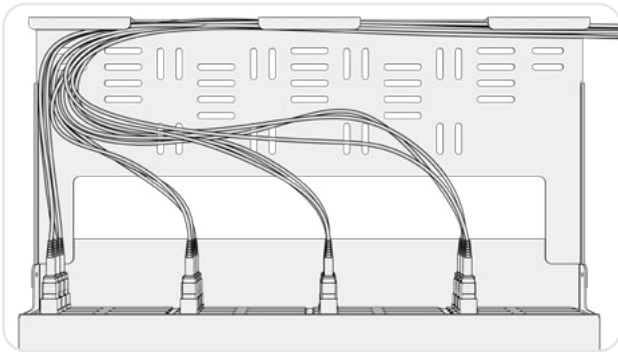

2.5: Fix the main jacket of the cable to the rear of the tray using cable ties.
(If fixing only tails to the tray then Velcro type ties are recommended.)

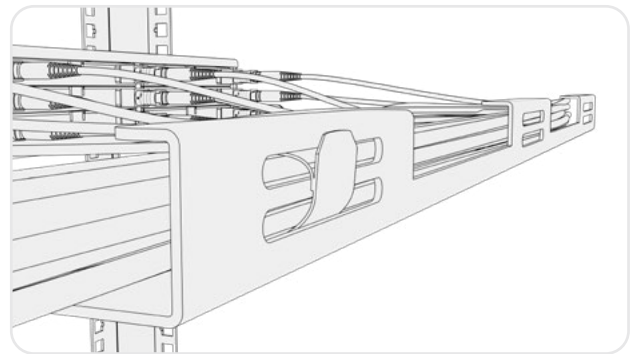
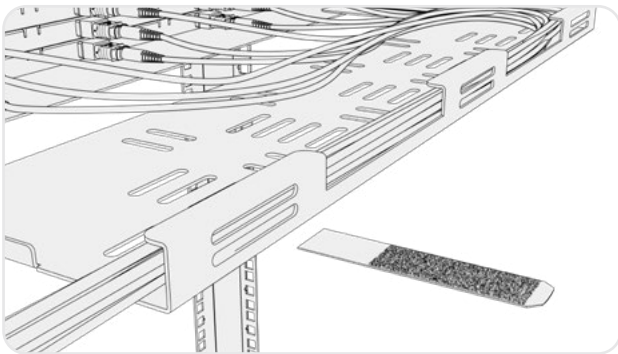

3. Front Cabling

3.1: Clean all end faces of the patch cords with lint free dry clean cloth.

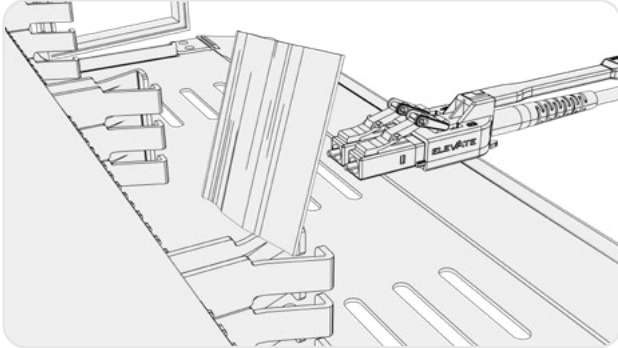

3.2: Clean all end faces of the cassettes and plug in all connectors.

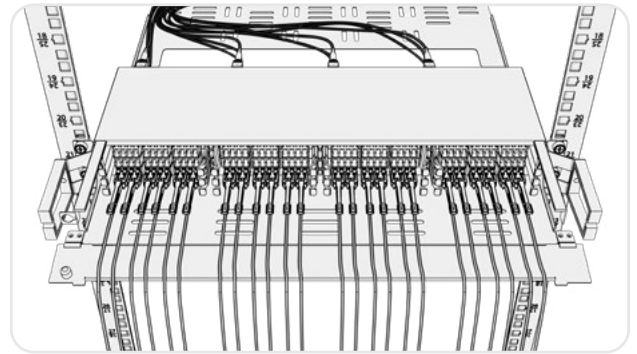
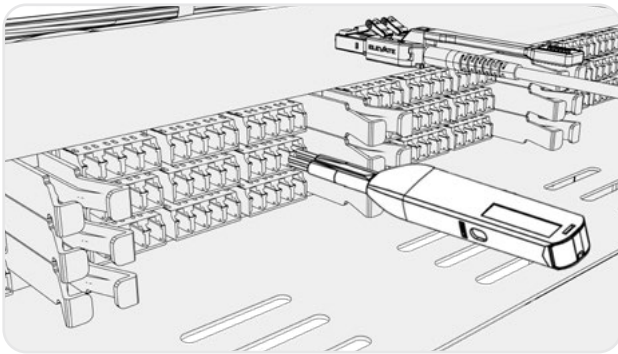

3.3: It is recommended to split the cabling 50% left and 50% right at the front of the cassettes.

3.4: It is recommended to place Velcro ties around each bunch of cables associated with a single cassette to allow easier access to individual cassettes.

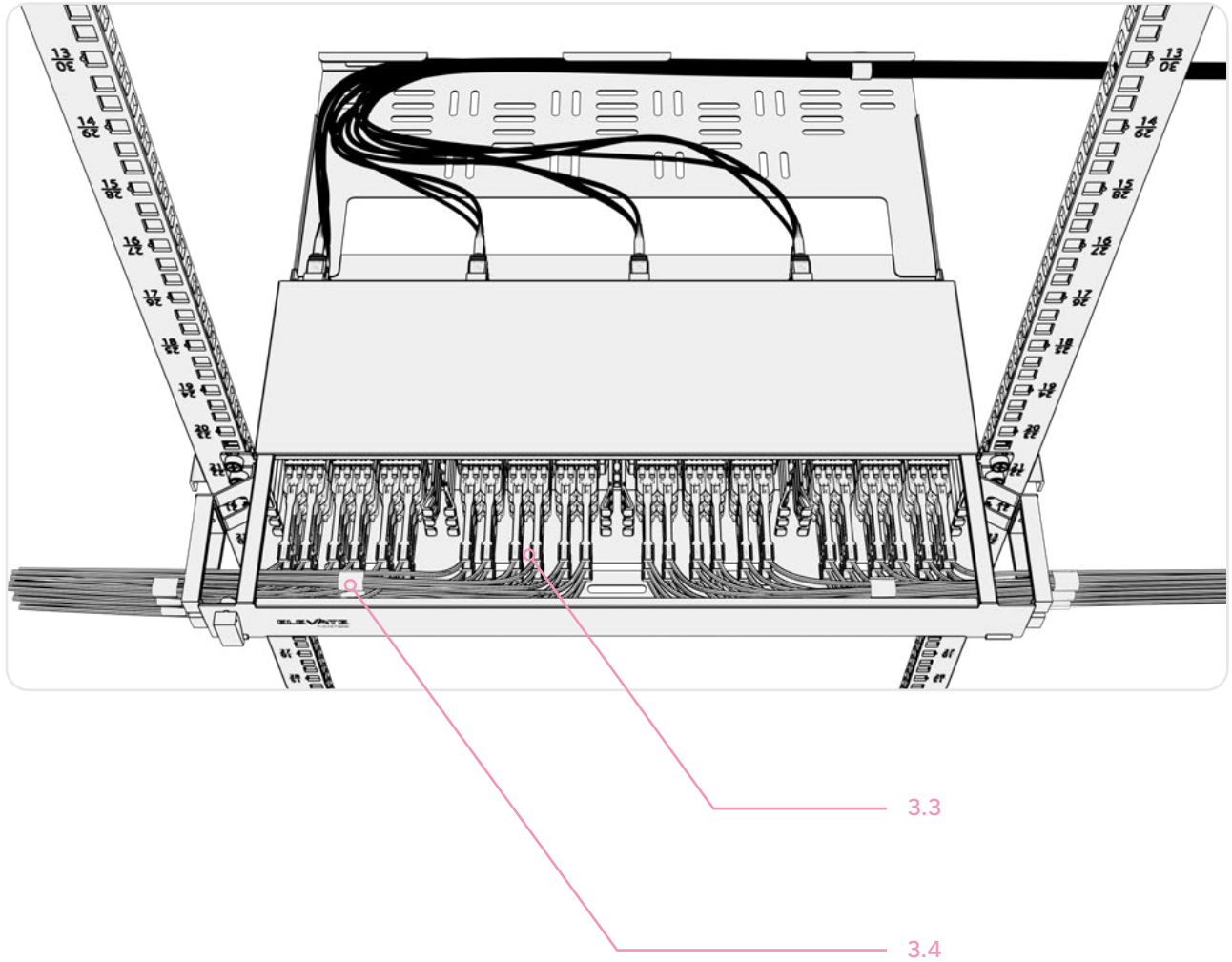



ELEVATE

Future Faster

elevate@excel-networking.com

elevate.excel-networking.com



 an excel solution